



DELTRIN* COUPLING INSTALLATION INSTRUCTIONS

Power Transmission Solutions
Regal Beloit America, Inc.
7120 New Buffington Road
Florence, KY 41042
Application Engineering: 800 626 2093
www.RegalPTS.com

FORM
3246-001E
Revised
September 2015

⚠ WARNING

- Read and follow all instructions carefully.
- Disconnect and lock-out power before installation and maintenance. Working on or near energized equipment can result in severe injury or death.
- Do not operate equipment without guards in place. Exposed equipment can result in severe injury or death.

⚠ CAUTION

- Periodic inspections should be performed. Failure to perform proper maintenance can result in premature product failure and personal injury.
- Do not use coupling above its torque or speed rating.

Properly installed, no maintenance is required on the MORSE DELTRIN* Coupling. It does not need lubrication. Make periodic visual inspections to check condition of coupling.

Catalog Number	Sprocket Gap
N410 to 430	9/32 IN.
N610 to 630	3/8 IN.

SPROCKET MOUNTING

1. Position Sprockets (Coupling halves) to allow a gap between sprocket as indicated in table.
2. Align the shafts as accurately as possible to obtain the longest service life from the coupling.

Angular Alignment: Coupling will tolerate a maximum of 1° angular misalignment, but for optimum life, a maximum of 1/2° is recommended. Angular alignment is checked by keeping both shafts stationary and taking measurement with a feeler gauge at the four points - A, B, C, D, (Fig. 1). The difference between A and C will give the error in alignment in the vertical plane. Likewise the difference between B and D gives the error in alignment in the horizontal plane.

Figure 1

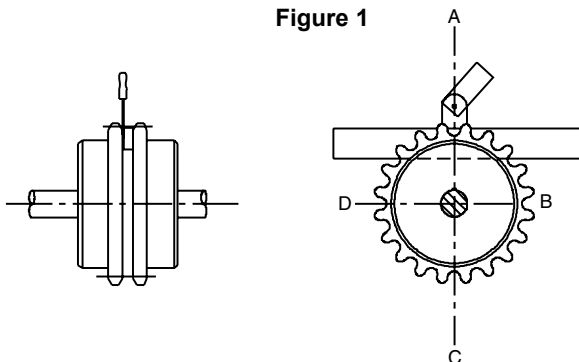
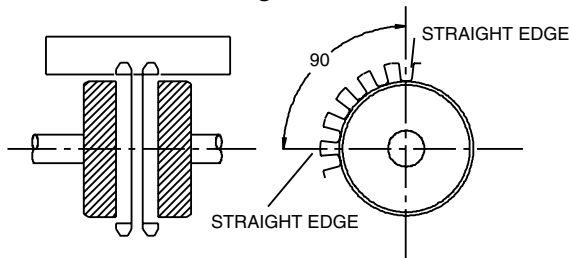

Figure 2



Parallel Alignment: Can be checked with a straight edge placed on the two sprockets as shown in (Fig. 2). Alignment should be checked in at least 2 places - at 90° intervals.

* Delrin is believed to be a trademark and/or registered trademark of E.I. DuPont De Nemours and Company, and is NOT owned or controlled by Power Transmission Solutions.

While efforts have been made to confirm the information herein, Power Transmission Solutions cannot and does not represent or warrant the accuracy of this information.

CHAIN HANDLING

1. When the shafts are properly aligned the chain will easily wrap the sprockets for final coupling assembly.
2. Final assembly of the coupling can be accomplished with either the slip fit connector supplied with retainer rings or the press fit grooved pin.
3. The slip fit pin will easily slide into place permitting the retainer rings to be snapped on with a pair of pliers.
4. Caution must be exercised when installing the press fit groove pin to insure that the Delrin link is not damaged. Support link immediately adjacent to the pin by means of a "C"-clamp, vise grip pliers or other similar devices as shown in (Fig. 3).
5. Disassembly of the press fit grooved pin can be accomplished by following Step 4, and driving out pin with a suitable drift pin. Slip fit pin can be removed after removal of retaining ring.

Figure 3

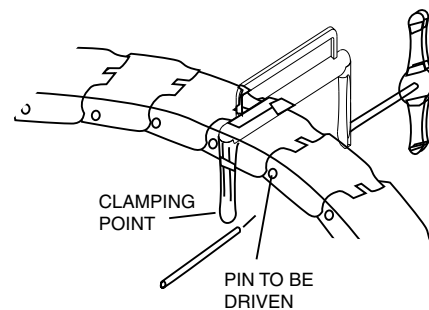

A Regal Brand

REGAL